

BERKELEY U-DS1400C ASSEMBLY INSTRUCTION

ITEM#	PARTS LIST	QTY
97-DS140A	A. Stand Frame	1
97-DS140B	B. Metal Guide	2
97-DS140C	C. Plastic Knob	4
97-DS140D	D. Hex Bolt	4
97-DS140E	E. Phillips Screw	14
84-2100C	30 x 42 White Top	1

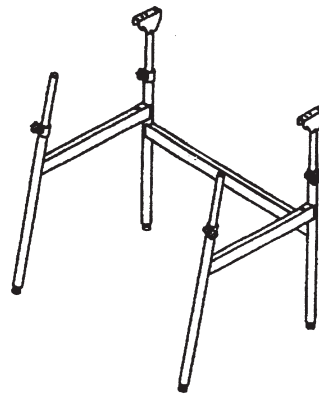

A. Stand Frame

B. Metal Guides



C. Plastic Knob

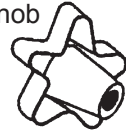

D. Hex Bolt

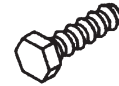

E. Phillips Screw

Your new U-DS1400C Berkeley Table has been designed and manufactured to enhance your productivity and efficiency. This sturdy folding table, properly assembled, will last through years of use. Follow the instructions below to assemble your table and refer to the enclosed parts list for part identification. Tools needed for assembly: phillips screwdriver, hammer, nail or awl, tape measure and pencil. Begin by unpacking the carton and making sure you have all parts listed.

1. Swing the left and right side legs out as shown. See Fig. 1

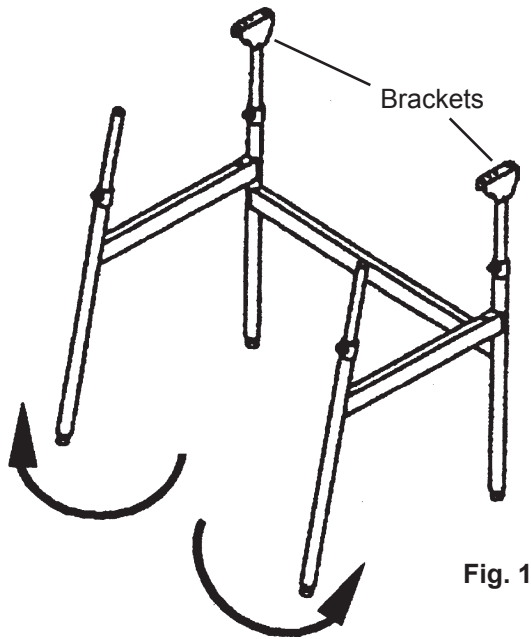

Fig. 1

2. Put the hex bolt [D] inside the clamp (See Fig. 2) and then attach knob [C] and tighten. (See Fig. 3)

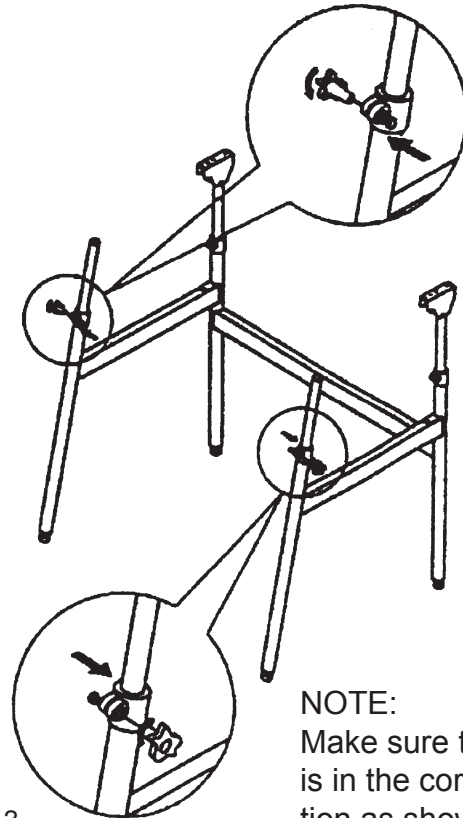

Fig. 2

Fig. 3

NOTE:
Make sure the collar is in the correct position as shown.
See Fig. 3

Any Questions with Assembly? We Can Help



PLEASE DO NOT RETURN THIS TABLE to the Store where you purchased it. If you are unable to assemble or parts are missing, **PLEASE** Call Customer Service at
Martin Universal Design, Inc.
313-895-0700 or Email: custservmud@aol.com

MARTIN
Universal Design, Inc.

Martin Universal Design, Inc. • 4444 Lawton Avenue, Detroit, MI 48208 USA
Tel: (313)895-0700 / Fax: (313)895-0709 • E-mail: Custservmud@aol.com

ONE YEAR GUARANTEE

This Martin Universal Design, Inc. product has a one year guarantee to be free from manufacturers defects during that period of use by the original purchaser. Items or parts subjected to extreme temperature or abuse or use of this product other than manufacturers intended purpose is not covered under this guarantee.

BERKELEY U-DS1400C TOP ASSEMBLY INSTRUCTION

If you purchase optional Tops B, D or P use the appropriate instruction for the top assembly.

Instructions for 30" x 42" C Top

This is the top included in the U-DS1400C Package

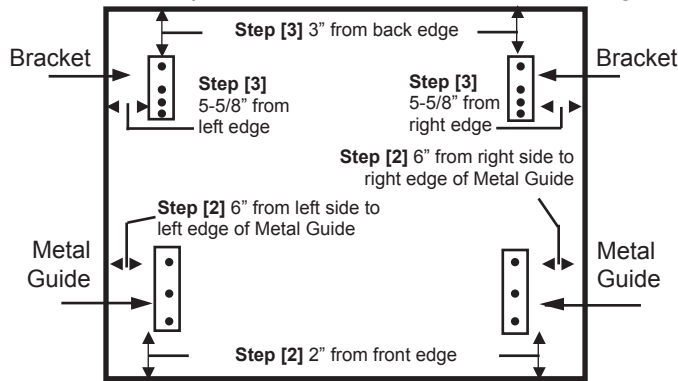

- Step 1. Place top onto carpeted floor. Laying best surface face down.
- Step 2. Attach Left and Right Metal Guides [B] by: Measuring 6" in from left edge and mark with pencil, repeat with right side. See above illustration. Measure 2" from front edge and make pencil mark. Repeat with other side for Metal Guides. Mark holes and then break surface with nail or awl. Secure with [3] Phillip screws [E] per metal guide [B].
- Step 3. Attaching Left and Right Brackets (already attached to base) by: Measuring 5-5/8" in from left edge and mark with pencil, repeat with right side. See above illustration. Measure 3" from rear edge and make pencil mark. Repeat with other side for Brackets. Break surface with nail or awl. Repeat with right side. Secure with [4] Phillip Screws.

Please Note:

Reason for breaking top surface by tapping a nail or awl in screw holes, is to make starting hole in surface to allow for easier attachment of screws.

Instructions for 24" x 36" B Top

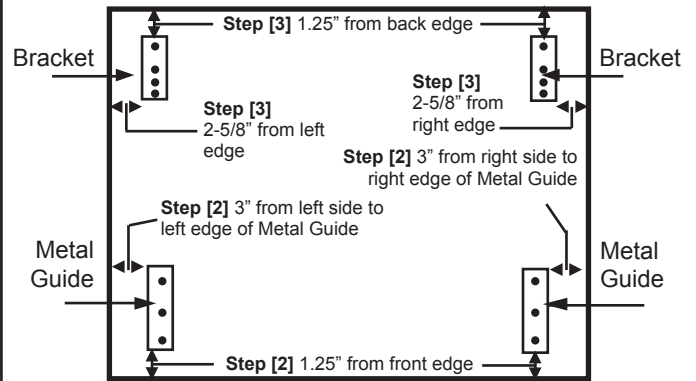

- Step 1. Place top onto carpeted floor. Laying best surface face down.
- Step 2. Attach Left and Right Metal Guides [B] by: Measuring 3" in from left edge and mark with pencil, repeat with right side. See above illustration. Measure 1.25" from front edge and make pencil mark. Repeat with other side for Metal Guides. Mark holes and then break surface with nail or awl. Secure with [3] Phillip screws [E] per metal guide [B].
- Step 3. Attaching Left and Right Brackets (already attached to base) by: Measuring 2-5/8" in from left edge and mark with pencil, repeat with right side. See above illustration. Measure 1.25" from rear edge and make pencil mark. Repeat with other side for Brackets. Break surface with nail or awl. Repeat with right side. Secure with [4] Phillip Screws.

Please Note:

Reason for breaking top surface by tapping a nail or awl in screw holes, is to make starting hole in surface to allow for easier attachment of screws.

Instructions for 31.5" x 48" D Top

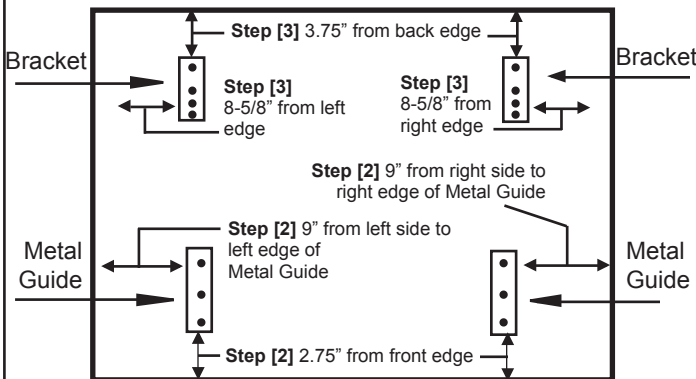

- Step 1. Place top onto carpeted floor. Laying best surface face down.
- Step 2. Attach Left and Right Metal Guides [B] by: Measuring 9" in from left edge and mark with pencil, repeat with right side. See above illustration. Measure 2.75" from front edge and make pencil mark. Repeat with other side for Metal Guides. Mark holes and then break surface with nail or awl. Secure with [3] Phillip screws [E] per metal guide [B].
- Step 3. Attaching Left and Right Brackets (already attached to base) by: Measuring 9" in from left edge and mark with pencil, repeat with right side. See above illustration. Measure 3.75" from rear edge and make pencil mark. Repeat with other side for Brackets. Break surface with nail or awl. Repeat with right side. Secure with [4] Phillip Screws.

Please Note:

Reason for breaking top surface by tapping a nail or awl in screw holes, is to make starting hole in surface to allow for easier attachment of screws.

Instructions for 36" x 48" P Top

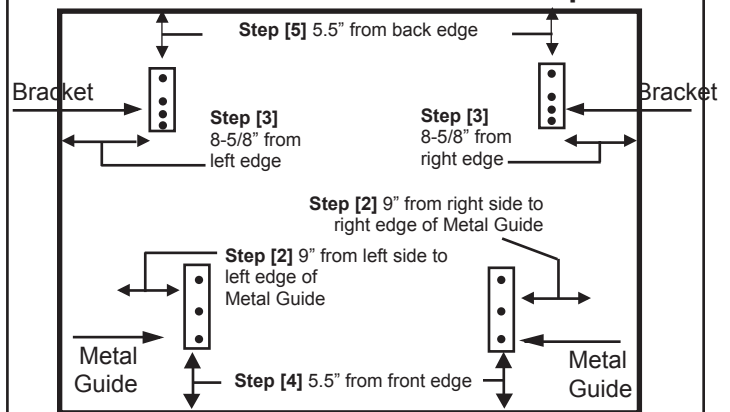

- Step 1. Place top onto carpeted floor. Laying best surface face down.
- Step 2. Attach Left and Right Metal Guides [B] by: Measuring 9" in from left edge and mark with pencil, repeat with right side. See above illustration. Measure 5.5" from front edge and make pencil mark. Repeat with other side for Metal Guides. Mark holes and then break surface with nail or awl. Secure with [3] Phillip screws [E] per metal guide [B].
- Step 3. Attaching Left and Right Brackets (already attached to base) by: Measuring 9" in from left edge and mark with pencil, repeat with right side. See above illustration. Measure 5.5" from rear edge and make pencil mark. Repeat with other side for Brackets. Break surface with nail or awl. Repeat with right side. Secure with [4] Phillip Screws.

Please Note:

Reason for breaking top surface by tapping a nail or awl in screw holes, is to make starting hole in surface to allow for easier attachment of screws.